

FEATURES

- 64-position linear taper
- Two nonvolatile wiper storage options
- Operates from +4.5 to +5.5-volt supplies
- Operating Temperature Range:
 - Industrial: -40°C to +85°C
- Electronic interface provides either digital or pushbutton control
- Low-cost alternative to mechanical solutions
- Standard Resistance Values
 - DS1809-010 10 kΩ
 - DS1809-050 50 kΩ
 - DS1809-100 100 kΩ

PIN ASSIGNMENT

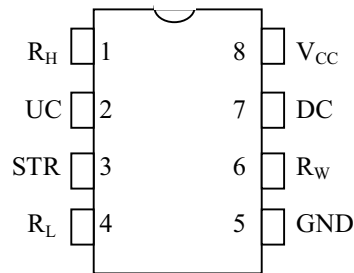

8-Pin DIP
 8-Pin SOIC (150-mil)
 8-Pin μSOP (118-mil)

PIN DESCRIPTION

V_{CC}	- Supply Voltage
R_H	- High End of Resistor
R_L	- Low End of Resistor
R_W	- Wiper Terminal
UC	- Up Control Input
DC	- Down Control Input
STR	- Storage Enable Input
GND	- Ground

DESCRIPTION

The DS1809 Dallastat is a nonvolatile digitally controlled potentiometer that provides 64 uniform wiper positions over the entire resistor range; including the high-end and low-end terminals of the device. The DS1809 is a low power device capable of operating from power supplies of +4.5V to +5.5V. The device is ideal for low-power, portable, or battery powered applications.

Wiper position is maintained in the absence of power. This is accomplished via the use of an EEPROM cell array. The device provides for two storage methods, which include an auto-store capability and a command-initiated storage function. The EEPROM cell array is specified to accept greater than 50k writes. Storage of the wiper position is discussed in the Wiper Storage section of this datasheet.

Wiper positioning is controlled via a patented dual pushbutton (or contact closure) interface. For simple pushbutton-controlled applications or CPU-generated control signals, external debounce circuitry is not needed. The control interface will support both repetitive pulse inputs and continuous pulse (“push-and-hold”) inputs. Repetitive pulse and continuous pulse control as well as timing diagrams are discussed in the section entitled “OPERATION.”

The DS1809 is available in standard 10 k Ω , 50 k Ω , and 100 k Ω resistor versions. The DS1809 is provided as an industrial temperature grade part only. Available packaging for the DS1809 include an 8-lead (300-mil) DIP an 8-lead (150-mil) SOIC, and an 8-lead (118-mil) μ SOP.

BLOCK DIAGRAM Figure 1

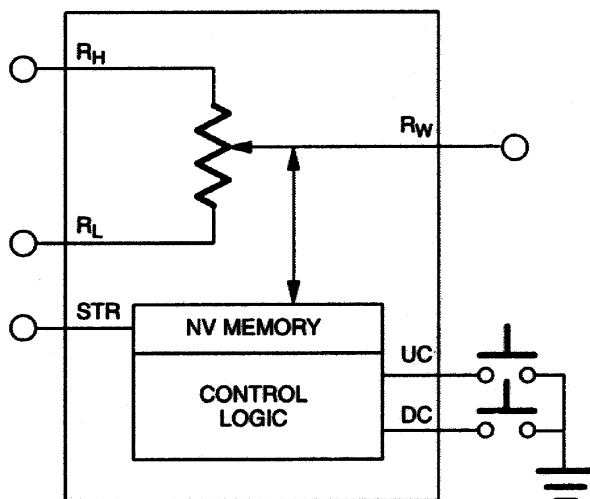

OPERATION

The DS1809 Dallstat is a digitally controlled, nonvolatile potentiometer. A block diagram of the DS1809 is shown in Figure 1. The DS1809 is a linear potentiometer providing 64-uniform wiper positions over the entire resistor range including the end-terminals. All three potentiometer terminals of the device are accessible. These terminals include R_H , R_L , and R_W . R_H and R_L are the end-terminals of the potentiometer. These terminals will have a constant resistance between them as defined by the potentiometer value chosen: 10 k Ω , 50 k Ω , or the 100 k Ω version. Functionally, R_H and R_L are interchangeable. The wiper terminal, R_W , is the multiplexed terminal and can be set to one of the 64 total positions that exist on the resistor ladder including the R_H and R_L terminals.

Control of the wiper (R_W) position setting is accomplished via the two inputs UC and DC. The UC and DC control inputs, when active, determine the direction on the resistor array that the wiper position will move. The UC (up control) control input is used to move the wiper position towards the R_H terminal. The DC (down control) control input is used to move wiper position towards the R_L terminal.

The control inputs UC and DC are active low inputs that interpret input pulse widths as the means of controlling wiper movement. Internally, these inputs are pulled up to V_{CC} via a 100 k Ω resistance. A transition from a high-to-low on these inputs is considered the beginning of pulse input activity.

A single pulse on the UC or DC input is defined as being greater than 1 millisecond but lasting no longer than $\frac{1}{2}$ second. This type pulse input will cause the wiper position of the Dallstat to move one position.

Multiple pulse inputs (repetitive pulse inputs) can be used to step through each wiper position of the device. The requirement for a repetitive pulse train on the UC or DC inputs is that pulses must be separated by a minimum high time of 1 millisecond. If this is not the case the Dallstat will ignore that pulse input.

A continuous pulse input ("push and hold") is defined as lasting longer than $\frac{1}{2}$ second. A continuous pulse input will cause the wiper position to move one position every 100 milliseconds following the initial $\frac{1}{2}$ -

second hold time. The total time to transcend the entire potentiometer given a continuous pulse input is provided by the equation:

$$\frac{1}{2}(\text{second}) + 62 \times 100 \text{ ms} = 6.7 \text{ (seconds)}$$

If the wiper position of the DS1809 is incremented to an end-position, it will stay at that position until the device receives an opposite direction input pulse command over the UC or DC inputs. For example, if the wiper position is incremented to the R_H terminal using the UC input control, it will stay at that position until UC is first deactivated, and then the DC input is activated to move the wiper position towards the R_L terminal.

The UC and DC control inputs are designed to support simple pushbutton inputs or CPU generated inputs. Figure 2 illustrates the requirements for pushbutton generated controls. For manual pushbutton controls all that is required are the desired pushbuttons to implement contact closure. No external debounce or timing circuitry is needed to support the pushbutton operation.

Applications using CPU generated controls must power the UC and DC control pins in a high state to avoid any inadvertent wiper position movement. To help prevent inadvertent wiper position movement during a power-up, the DS1809 locks out the control port inputs for a minimum time of 10 ms.

WIPER STORAGE

As stated earlier, the DS1809 provides for two methods of nonvolatile wiper storage using internal EEPROM memory cells. These two methods include an autostore configuration and a command initiated storage operation, both of which utilize the STR input pin. The EEPROM cell array of the DS1809 is designed to accept greater than 50k writes.

AUTOSTORAGE

The autostore configuration is designed to provide wiper position storage as the part powers down; writing the current wiper position into memory. The configuration for initiating the automatic storage capability of the DS1809 is shown in Figure 3. As shown in this configuration, two external devices are required to insure proper wiper storage. This includes a Schottky diode and a 10-uf capacitor. The automatic store configuration will cause the DS1809 to initiate storage of wiper position when power (V_{CC}) to the device is removed. The 10-uF capacitor and Schottky diode are used to provide supplemental power for wiper storage.

COMMAND-INITIATED WIPER STORAGE

The DS1809 will also support a command-initiated wiper storage operation during powered conditions. For command initiated storage the STR pin should be held in a low state on power-up; otherwise the part will assume an autostore configuration. As shown in Figure 5, a low-to-high pulse lasting at least 1 μ s on the STR input will cause the DS1809 to initiate the storage of the current wiper position into EEPROM when V_{CC} is present.

PUSHBUTTON CONFIGURATION Figure 2

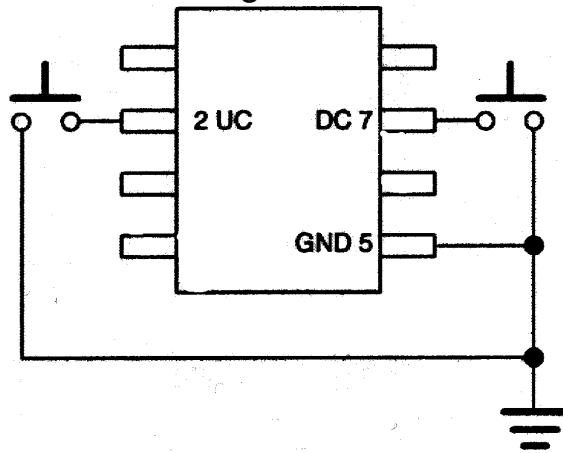

It is assumed that the STR input will be controlled by either external logic or CPU driven. No external capacitors or diodes are needed for the command-initiated storage operation.

The STR input will take precedence over the pushbutton inputs UC and DC.

AUTOSTORE CONFIGURATION Figure 3

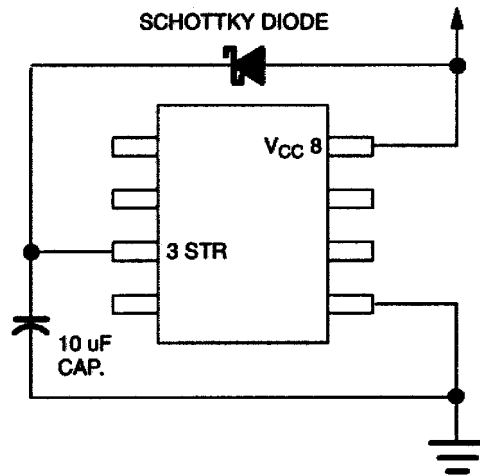

PUSHBUTTON TIMING DIAGRAMS Figure 4

CONTINUOUS AND SINGLE PULSE INPUTS

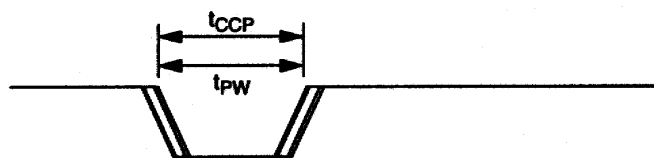

REPETITIVE PULSE INPUTS

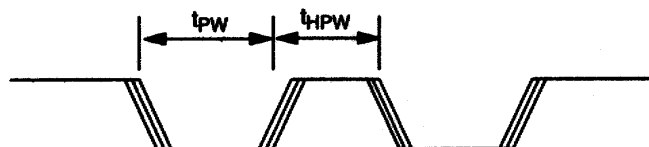

If during any pushbutton activity the STR input is activated, pushbutton operation will be suspended until the storage of EEPROM has been completed. Once complete, pushbutton inputs, if still active, will resume from the point of suspension. Command initiated storage operations will require a minimum of 4 ms to complete the storage operation. This 4 ms is measured from the rise of STR input (see Figure 5).

For applications not requiring or using the nonvolatile memory feature of the DS1809, it is recommended that the STR input be connected to GND.

COMMAND INITIATED WIPER STORAGE - Figure 5

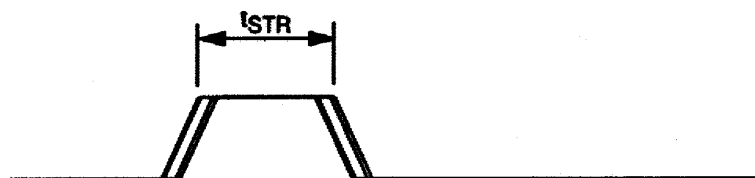

ABSOLUTE MAXIMUM RATINGS*

Voltage on Any Pin Relative to Ground	-1.0V to +7.0V
Operating Temperature	-40°C to +85°C; industrial
Storage Temperature	-55°C to +125°C
Soldering Temperature	See J-STD-020A Specification

* This is a stress rating only and functional operation of the device at these or any other conditions above those indicated in the operation sections of this specification is not implied. Exposure to absolute maximum rating conditions for extended periods of time may affect reliability.

RECOMMENDED DC OPERATING CONDITIONS (-40°C to +85°C)

PARAMETER	SYMBOL	MIN	TYP	MAX	UNITS	NOTES
Supply Voltage	V_{CC}	+4.5		5.5	V	1
Resistor Inputs	R_L, R_H, R_W	GND-0.5		$V_{CC}+0.5$	V	2
GND	GND	GND		GND		1

DC ELECTRICAL CONDITIONS (-40°C to +85°C)

PARAMETER	SYMBOL	MIN	TYP	MAX	UNITS	NOTES
Supply Current Active	I_{CC}		500	1000	μA	5
Standby Current	I_{STBY}			25	μA	6
Logic Input High	V_{IH}	+2.0		$V_{CC}+0.5$	V	6,11
Logic Input Low	V_{IL}	-0.5		+0.8 +0.6	V	6,11
Input Leakage	I_{IL}	-1		+1	μA	3
Wiper resistance	R_{WIPER}			400	Ω	
Wiper Current	I_W			1	mA	
Storage Pin Current (STR)	I_{SP}		5	8	μA	12,18
Wiper Storage Time	t_{WST}	4			ms	19

AC ELECTRICAL CONDITIONS

PARAMETER	SYMBOL	MIN	TYP	MAX	UNITS	NOTES
Single Input Pulse Width	t_{PW}	1		DC	ms	4,5,7,9
Repetitive Pulse High Time	t_{HPW}	1		DC	ms	4,5,7,8,9
Continuous Pulse	t_{CCP}	1		DC	ms	4,5,7,8,9
Storage Control Pulse	t_{STR}	1			μ s	10,12
Capacitance	C_{IN}		5	10	pF	10

ANALOG RESISTOR CHARACTERISTICS ELECTRICAL CONDITIONS

PARAMETER	SYMBOL	MIN	TYP	MAX	UNITS	NOTES
End-to-End Resistor Tolerance		-20		+20	%	14
Absolute Linearity		-0.6		+0.6	LSB	15
Relative Linearity		-0.25		+0.25	LSB	16
-3 dB Cutoff Frequency	f_{CUTOFF}				MHz	17
Temperature Coefficient			750		PPM/ ^o C	14

NOTES:

- All voltages are referenced with respect to ground.
- Voltages across the potentiometer terminals (R_L , R_W , R_H) cannot exceed V_{CC} or go below ground by 0.5V.
- Inputs UC and DC are internally pulled-up with resistance of 100 k Ω .
- UC and DC inputs are internally pulled-up to V_{CC} via a 100 k Ω resistor.
- Active current is specified when the inputs UC or DC are active.
- Standby current is the current consumed when the UC, DC, and STR inputs are inactive.
- Input pulse width is the minimum time required for an input to cause an increment or decrement.
- Repetitive pulse inputs on UC or DC will be recognized as long as they are within 500 milliseconds of each other. Pulses occurring faster than 1 ms apart may not be recognized as individual and separate pulses.
- Input pulse timing has tolerances to $\pm 10\%$.
- Capacitance values apply at 25°C.
- For $V_{CC} = 5V \pm 10\%$, maximum $V_{IL} = +0.8V$. Input logic levels are referenced to ground.
- If not used STR should be connected to ground.
- The DS1809 is offered in three values: 10 k Ω , 50 k Ω , and 100 k Ω .

-
14. Valid at 25°C only.
 15. Absolute linearity is used to compare measured wiper voltage versus expected wiper voltage as determined by wiper position. The DS1809 is specified to provide a absolute linearity of ± 0.60 LSB.
 16. Relative linearity is used to determine the change in voltage between successive tap positions. The DS1809 is specified to provide a relative linearity specification of ± 0.25 LSB.
 17. -3 dB cutoff frequency characteristics for the DS1809 depend on the potentiometer's total resistance. DS1809-010: 1 MHz; DS1809-050: 200 kHz; and the DS1809-100: 100 kHz.
 18. Current leakage on the input control storage pin will require a typical 5 μ A and maximum 8 μ A to implement the auto-storage feature.
 19. A minimum time of 4 milliseconds between 2.2 volts and 1.7 volts is required on the input to the STR terminal when using the part in the auto-storage configuration. The 2.2-volt to 1.7-volt range is a worst case condition for meeting the power-down storage requirements of the part.

ORDERING INFORMATION

ORDERING NUMBER	PACKAGE	OPERATING TEMPERATURE	VERSION
DS1809-010	8-PIN DIP	-40C to +85C	10 k Ω
DS1809-050	8-PIN DIP	-40C to +85C	50 k Ω
DS1809-100	8-PIN DIP	-40C to +85C	100 k Ω
DS1809U-010	8-PIN μ SOP	-40C to +85C	10 k Ω
DS1809U-050	8-PIN μ SOP	-40C to +85C	50 k Ω
DS1809U-100	8-PIN μ SOP	-40C to +85C	100 k Ω
DS1809Z-010	8-PIN SOIC	-40C to +85C	10 k Ω
DS1809Z-050	8-PIN SOIC	-40C to +85C	50 k Ω
DS1809Z-100	8-PIN SOIC	-40C to +85C	100 k Ω